

"BETWEEN-US"

VOL. 19 ISSUE 3

MARCH 2011

March 1951 Vol. 7, No. 10

July 1956, Vol. 13, No. 2

A "Narrowback" (Hivven Help Him) Speaks for the Irish

YOU don't have to look at me through green-colored glasses to see that I'm Irish. By name and by features I bear the unmistakable stamp of the Emerald Isle. But to the people of the Ould Sod, I am what they call a 'Narrowback'--one who is born of Irish parentage in this country and considered by them to be Irish in name only.

Consequently, I expect to get my come-uppance for my presumption in acting as their self-appointed spokesman.

The Irish, God love 'em, are first in many things. At times it almost seems that they are first, numerically speaking, in Alcoholics Anonymous. Oh, the legions of Reardons, O'Briens, Flynn's, Murphys, O'Reillys, etc., who perforce seek the sanctuary of AA sobriety! God must really watch over the Irish--because he puts so many of them in touch with our wonderful organization.

("Narrowback" Continued on page 6)

<i>WHAT'S INSIDE</i>	<i>Page</i>
Office Financials	2
Secretary Meeting Notes	3
District Meetings/Corrections	4, 5
Club Info and Meetings	10, 11, 12
When & Where, Open Meetings	12, 13
Interesting Stuff	14 thru 20

None So Deaf

ONCE a few years ago I tried, with meagre success, to sell hearing aids. It was only one of many dreams of becoming a hot-shot salesman and getting rich, and it resulted like so many of those dreams in time and gasoline lost, but I learned some things that may interest you.

Hard-of-hearing people--never, never say "deaf"--some people think are a queer lot. Their affliction almost always grows on them imperceptibly so that they are the last ones to notice it. They insist other people do not speak loud or distinctly enough and the habit of not listening grows until they miss more and more of life; and oral intercourse, unless they are dominating the conversation, becomes a rarity; consequently the inevita-

("Hearing" Continued on page 7)

Between-Us Subscribers!

Due to some strange and unique postal bulk mail pricing, it is cheaper for us to mail the group subscription in two separate envelopes of three each. This means that the group will receive six copies instead of five for the same low price of \$18.00.

Also, individual subscribers will receive three copies in their envelope. The price will remain the same, \$9.00. Share the extras with your friends. Thank you.



Milwaukee Central Office, Profit and Loss, Income January 2011

Ordinary Income/Expense		
Income		
4000 · Literature Sales		12,882.34
4050 · Between us		464.75
4070 · Contributions		4,668.20
4080 · Gratitude boxes		6,129.95
4130 · Personal Contri.		51.22
4150 · Other Income		114.15
4830 · Sales Discounts		9.94
48900 · Shipping and Delivery Income		272.33
Total Income		24,592.88
Cost of Goods Sold		
5000 · Literature		8,428.96
52900 · Purchases - Resale Items		71.03
Total COGS		8,499.99
Gross Profit		16,092.89
Expense		
51100 · Freight and Shipping Costs		19.93
59900 · POS Inventory Adjustments		-2.39
6000 · Advertising and Promotion		114.00
6170 · Computer and Internet Expenses		36.00
6200 · Conferences & conventions		96.00
6260 · Shipping and freight		284.16
6330 · Insurance Expense		660.00
6500 · Office		2,861.51
6600 · Payroll		10,389.07
Total Expense		14,458.28
Net Ordinary Income		1,634.61
Other Income/Expense		
Other Expense		
Balancing Adjustments		0.00
Total Other Expense		0.00
Net Other Income		0.00
Net Income		1,634.61
CD Prudent Reserve	\$84,439.24	
Money Market	24,184.79	
Checking	3,500.93	

AREA 75 EVENTS CALENDAR

1. Go to Area 75 website at: area75.org, 2. Look for the Area 75 Events Calendar on the right side of the page. 3. Events listed are color coded according to the area office that listed them. 4. Click on the small down arrow at the top right hand corner of the Events listing for the color "key" to the area's events. 5. Click on the small down arrow in the middle (next to the date) to view a specific date or just use the scroll button to move up and down through the days listed.

Secretary Meeting, February 8, 2011

Groups represented: 14, 59, 83, 200, 201, 232, A New Awakening, A New Day, Another Chance Tuesday Night, Badger Group, Big Book Readers, Brown Deer Monday Night, Daily Reprieve Men's, Fireside, Hales Corners Tuesday Night, Honest and Able, How It Works, Keep Passing It On, LGBT Friendly, Living Sober Wednesday, Mayflower, Monday Night Menomonee Falls Action, New Beginnings Mukwonago, New Beginnings Oconomowoc, New Berlin Big Book Tue, New Berlin Friday, New Hope Trinity UCC, Participation Gp, Pick-a-Topic, Primary Purpose Gp, Serenity at the Vineyard HP, Solutions Intergroup Friday and Sunday, Sun Morning Sunlight, Sunday Night Surrender, Sussex Friday Night Action, T-N-T, Traditions Meeting Open Disc, Tue Night Grapevine, WELL Big Book, Willingness Gp. I'm sorry if I have missed anyone that was at the meeting.

Meeting opened by Jim B. at 7:00 p.m. Bank balances:
Business Checking: \$3,500.93
Money Market Savings: \$24,184.79
Prudent Reserve CD's: \$84,439.24

Time to return the Gratitude Boxes. 382 boxes have been returned with a total of \$15,592.79 to date. If you notice that your group hasn't returned the box...try to get it into the

office as soon as possible.

Between-Us subscriptions: if your group hasn't paid yet for year 2011, now is the time. \$18.00 for 6 copies per month. Individual subscriptions are available at \$9.00 (3 copies).

41st Annual City Wide Jamboree for the Central Office will be held on Saturday September 17, 2011. at the Milwaukee County Zoo. \$25.00, AA Speaker: Mildred F. from Toronto.

Bill, District 16 Special Needs Chair was the guest speaker. Bill mentioned the special needs of our military personal returning home. There are lots of men and women at the VA Hospital in need of help.

Meeting closed at 7:45 pm. Next meeting is March 8, 2011. at 7p.m.

Deaf, Deaf/Blind and Hard of Hearing AA Meeting List, ASL Interpreter available

- Thursdays at 8:00 p. St John Vianney Parish 1755 N. Calhoun Rd, Brookfield WI. **Open AA Meeting for everyone—Third Thursday of Month**, Wheelchair entrance available.

Meetings are weekly closed AA meetings, except where otherwise noted. All meetings are Non-Smoking. **ASL Interpreter available.**

Contact John R. through Voice Relay Service 800-973-8024 / 414-546-3246 TTY/Voice.

E-mail at: jreskel@wi.rr.com

Contact George B. through Video Relay Service 866-327-8877 / 414-903-8905 TTY/VP

AA Groups Need Your Support

- **Monday at 1:30 pm.**
Bethesda Community Center
2845 W Fond du Lac Ave
Milwaukee, WI 53210

- **Thursday at 12:15 pm.**
- **Wednesday 5:30 pm. Topic**
both meet at
St. John's Cathedral Complex,
831 N. Van Buren St.
Milwaukee, WI 53202

Broken Arrow Gp.
- **Friday at 6:30 pm.**
Serenity Club, 3677 E Pulaski
Cudahy WI 53110

Perfect for a midday break, or a quick meeting before heading home. Get your meeting in early and relax.

Orientation for GSR's

Second Tuesday of each month, 6:30 p.m. prior to the secretary's meeting, at the Milwaukee Central Office. Or, call Ken G. 608-221-2891, sherwood1@charter.net, to arrange for G.S.R. orientation at your district or workshop.

DISTRICT MEETINGS

DISTRICT

1. JACKSON, LaCROSSE, MONROE, TREMPLEAU & VERNON CNTY'S 2nd Sat. of month, 1:00 p.: Faith Evangelical Free Church, 6644 Hwy 16, Sparta WI 54656 (One mile west of Sparta)

2. GREEN LAKE & MARQUETTE CNTY'S & PART OF WAUSHARA CNTY 4th Sun. of month, 4:30 p., St. John's Church 1211 W. Main St., Princeton

3. MANITOWOC & SHEBOYGAN CNTY'S 3rd Wed. of month, 6:30 p., Even numbered months at 1907 Club, 2908 N. 21st St., Sheboygan. Odd numbered months: Alano Club, 404 S 29 St Manitowoc

4. MILWAUKEE CNTY (1 of 9) 2nd Thr. of month, 6:00 p., Alano Club, 1521 N. Prospect Av.

6. WALWORTH CNTY 2nd Wed. of month, 7:30 p., Walworth Alano Club, 611 E. Walworth St., Delavan

7. KENOSHA CNTY 3rd Sun. of month, 4:00 p., Kenosha Alano Club, 630 56th St.

8. ROCK CNTY (1 of 2) 1st Fri of month, 6:30 p., Good Shepard Lutheran Ch, 2447 Park St., Beloit

9. CRAWFORD, GRANT, IOWA and LAFAYETTE CNTY'S Last Mon. of month, 6:30 p., West View Methodist, Madison & Hathaway, Platteville,

10. Spanish District, at large. Contact Ernesto N. at 414 645-8591. Meets every Tue. at 5:00 p., 1663 S. 6th Street, Milw.

11. JEFFERSON CNTY Meets last Wed. at 5:30 p.m. Moravian Church, 301 College St., Lake Mills,

12. WASHINGTON CNTY 1st Wed. of month, 6:00 p., Jansen Family Park, Schuster Dr. West Bend

13. WAUKESHA CNTY (1 of 4) 1st Sun. of month, 4:00 p, St. Matthias Church, 111 E. Main, Waukesha

14. MILWAUKEE CNTY (1 of 9) 4th Wed. of month, 7:00 p, Milwaukee Central Office 7429 W Greenfield Ave., P.O. Box 13011, Wauwatosa WI 53226

15. MILWAUKEE CNTY (1 of 9) Last Sunday of month, 5:30 p, Milwaukee Room 933 E. Center St. Milwaukee

16. MILWAUKEE CNTY (1 of 9) 1st Wed. of month, 7:00 p, Faith United Methodist Church, 400 S. 91st St.,

17. RACINE CNTY (1 of 2) 3rd Sun. of month, 1:00 p, Grove Club, 1037 Grove Ave., Racine

18. Combined with District 2. See "District #2"

19/37. RICHLAND & SAUK CNTY'S Last Wed. of month, 6:15 p, in Rm 14, at Baraboo Civic Cntr.

20/21 DANE CNTY (1 of 2) Last Tue. of month, 6:30 p, Monona Community Center, 1011 Nichols Rd., 53716

22. MILWAUKEE CNTY (1 of 9) 2nd Thr of month, 6:00 p, Alano Club, 1521 N. Prospect Ave.

23. DODGE CNTY 1st Wed of month at 7:00 p, Dodge Cnty Alano Club, 115 N. Lincoln, Beaver Dam, call to confirm 920-583-3142

24. OZAUKEE CNTY 3rd Tue. of month, 6:30 p., Advent Lutheran, W63N642 Washington, Cedarburg

25. FOND du LAC CNTY 2nd Tue. of month, 6:30 p., Gratitude Club, 295 Ruggles St., Fond du Lac

26. DANE CNTY Combined with District 20

27. MILWAUKEE CNTY (1 of 9) 3rd Sat. of month, 9:00 a.m. 12 Step Club, 4102 W. Townsend

28. MILWAUKEE CNTY (1 of 9) 3rd Mon. of month, 7:00 p, Bay View United Methodist 2772 S Kinnickinnic Ave. Bay View, WI 53207

29. MILWAUKEE CNTY (1 of 9) 1st Mon. of month, 7:00 p, St. Alphonsus School, 6000 W. Loomis Rd., Greendale (enter west side/rear of school)

30. ROCK CNTY (1 of 2) 1st Fri. of month, 6:30 p. 734 Railroad St., Janesville. (Unity Group)

31. COLUMBIA CNTY 3rd Sun. of month, 6:30 p., Pardeeville Village Library, 119 N. Main St. Pardeeville, South entrance, lower level.

32/33. WAUKESHA CNTY (1 of 4) 3rd Sun. of month, 1:00 p, Galilee Lutheran Church, N24 W26430 Crestview Dr., Pewaukee.

34. WAUKESHA CNTY (1 of 4) 1st Tue. of month, 6:30 p, Northwest Alano Club, N88W17658 Christman Rd., Menomonee Falls

35. GREEN CNTY Quarterly, when called.

36. RACINE/KENOSHA (1 of 2) 2nd Tues. month 6:00 p.m., 12 & 12 Club, 724 N Pine St., Burlington

37. JUNEAU CNTY No information available.

SEND ADDITIONS AND CORRECTIONS TO:

Greater Milwaukee Central Office
7429 W. Greenfield Ave, West Allis, WI 53214,
dan@aamilwaukee.com

CORRECTIONAL INSTITUTIONS

ETHAN ALLEN SCHOOL, Wales, WI 53183
Open speaker meetings every Tuesday at 6:00 p.m. (no meeting on the 5th Tuesday of a month). Need facilitators and speakers for 2010, contact Mark G at 262-896-9526 mgukich@wi.rr.com or Perry C. at 414-588-1638 pgcristan@sbcglobal.net

TAYCHEEDAH CORRECTIONAL, Meetings are held every other Tuesday, 5:30 -7:30 p.m. Contact: Deb L-H. (920)238-7414

FEDERAL CORRECTIONAL INSTITUTION, P.O. Box 1085 Oxford, No Meeting!

FEDERAL CORRECTIONAL Satellite Camp, New Path Group, P. O. Box 1085 Oxford, WI. Meetings Wed. at 1:30 p.m.

OAK HILL AA GROUP, OAK HILL WCI 5212 Hwy M, P.O. Box 140 Oregon, WI 53575 Meetings Wednesday at 7:00 p.m. and Sunday at 6:30 p.m. Contact: Rick B. (608) 235-5154

THOMPSON FARM, RT. 2 DEERFIELD, WI. Closed meeting Tuesday at 8:00 p.m. Contact: Tom Dickert, (608)764-5755

SOUTHERN OAKS GIRLS SCHOOL, Union Grove WI, AA Wednesday 5:55 p.m. and Alateen Tuesday 6:30 p.m. Contact: Marty S. (414) 975-8903 for clearance

ROBERT ELLSWORTH CORRECTIONAL, 21425A Spring St., Union Grove, 53182 AA Wed. 7:30 PM, AA Mon. night 6:00 p.m. and 7:00 p.m. and Wed, at 7:00 p.m. Contact Jo

(262) 551-7371 or Karelyn P. 414-327-7915.

KETTLE MORAIN CORRECTIONAL, Box 31, W9071 Forrest Dr., Plymouth, WI, AA Thr. at 6:00 p.m. Contact Mike L (920) 898-4782.

MILWAUKEE COUNTY HOUSE OF CORRECTION, 8885 S. 68th St. Franklin WI. **AA Women's** Saturday 10:00 a.m. Contact: Chris S. (414) 329-9310 or **AA Men's** on Sunday at 7:00 p.m. Contact: Dennis D. (414-372-8324

MILWAUKEE COUNTY JAIL 9th & State Milwaukee WI. Clearance needed at both facilities. **AA Women's** Sat. at 5:00 p.m. Contact Felisa C. (414) 672-6724. **AA Men's** Thr. at 7:00 p.m. Contact: John A. at (414) 915-9512

MILWAUKEE SECURE DETENTION CENTER, 1015 N. 10th St. Milw. Sunday Nights from 6:30 p. to 7:30 p., Men & Women, Call Marty S. at 414-975-8903 for information

WAUPUN CORRECTIONAL INSTITUTION AA Meeting Sat. , 8:00a.m.-9:30 a.m. Contact Dale C. 920-387-4229 after 5 p. clearance.

FOX LAKE CORRECTIONAL, Box #147, Fox Lake, WI 53933 Closed meetings Tue. & Fri. from 6:00 -8:00 p.m.

JEFFERSON COUNTY JAIL 411 S. Center St., Jefferson, WI, Mng. held on Mon. at 7:00 p.m., Contact: Scott N. 920-397-0170

RACINE CORRECTIONAL INSTITUTION for MEN Mtngs: Sun. 8:30 AM, Dane Rx Unit Wed. 7:00 p. Contact: Bill H. (262) 633-1851

MILWAUKEE COUNTY CORRECTIONS COMMITTEE: Meets 3rd Wednesday of each month at Faith United Methodist Church, 400 S. 91st St (91st & Adler). All Milwaukee **County Corrections donations should be sent to: MCCC, PO Box 270544, Milwaukee WI 53227-0544.** Call coordinator: Steve G at 414-339-7691, email: stevegravatt@yahoo.com with questions. Treasurer Bill E. at 414-433-3507. Corrections volunteers must go through the committee to get AA literature to take into the various facilities. Milwaukee Central Office no longer handles the funds.

Area 75, Southern Wisconsin, Calendar of Events 2011

Madison Senior Center (MSC), 330 W. Mifflin St. Madison, WI, except where otherwise noted.

- Mar 27, Delegate Workshop
- Apr 10, Pre-Conference Assembly
- May 1-7, General Service Conference NYC
- May 20-22, Spring Conf., Sheraton Brookfield
- Jun 26, Summer Service Assembly
- Oct 16, Fall Service Assembly
- Nov 11-13, East Central Regional, Miamisburg OH

- Milwaukee Central Office:** 7429 W Greenfield Ave, West Allis, WI 53214 gmco@aamilwaukee.com
- Area 75 Treasurer:** PMB #167, 5464 N Port Washington Rd., Glendale WI 53217
- General Service Office:** G.S.O, P O Box 459, Grand Central Station, New York, N.Y. 10163
- Area 75 Corrections, Bridging the Gap and Treatment write to:** PMB # 170, 5464 N Port Washington Rd., Glendale WI 53217

("Narrowback" Continued from page 1)

March 17th celebrates St. Patrick's Day. He, so the legend goes, chased the snakes out of Ireland. But great as was his achievement, AA goes him one better--and covers a lot more territory in the process. It chases the snakes out of the lives of many alcoholics in the United States, Australia, Sweden and in every other country where there is an AA group--even in the self-same Ireland!

Speaking for myself, snakes never bothered me. It was those alcoholic leprechauns--those little 'green men' (not Irishmen) who used to stand outside my door and dare me to come out and fight. D.T.'s, you know! Sure and it wasn't a great day for me to hear those little 'green men' taunting me between hic-coughs (theirs and mine.) But eventually the great day did come! Call it the luck of an Irishman (once removed)--but AA and I found each other.

When I say I found AA, I mean just that. I pounced on the Program as if I had made a great discovery.

I drank in the words of the members (my first constructive 'drinking,' I might add.) I looked upon each speaker as if he were a football coach saying: 'Come on boys, get in there and fight!' And fight I did. I fought hard against taking the first drink. Pugnacious was the word for me. And I noticed something. I noticed that the Reardons, O'Briens and Murphys--and many of the other Irish who joined AA--gave that first drink one whale of a fight, and generally won out.

Being of Irish descent and belliger-

ent by extraction, I am proud of the success of the Irish with this Program--and their increasing numbers. Once they accept AA, they are forthright and unequivocal, honest and declarative in how it works for them.

That's the Irish way of doing things. If they have an opinion, they express it unmistakably. If they believe in God, they call him God and don't temporize with vague references to a Higher Power.

It's so characteristic of them. When an Irishman gets drunk, he doesn't hide timidly at home behind the curtains or Venetian blinds, or remain speechless at a bar. Brother, he's drunk--and what of it! His behavior is uninhibited and his positive opinions on life, liberty and the pursuit of happiness are outspoken. Naturally, he's the same person in AA. . . only sober!

There are so many Irish in this organization, it reminds me of an old wisecrack (and here's where a shillelagh bounces off my head again): "You don't have to be Irish to join AA--but it helps!"

Reprinted w/permission AA Grapevine, Inc

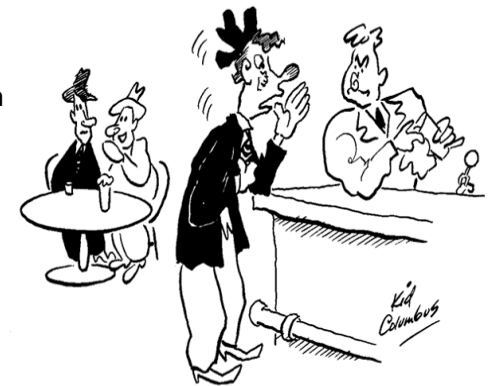

I'm a sick man, O'Riley. Ask any A.A.

ble withdrawal leaving them lonesome and friendless. Strangely enough it never occurs to the victims that the failing is theirs or that they can do anything about it. It is generally some relative or relatives who become desperate and who persuade them to contemplate a hearing aid, and almost never will they try one when the idea is first suggested or buy one on the first demonstration of the instrument.

Every hard-of-hearing person has a different pattern--each one has certain frequencies that he can hear fairly well and others that come in weaker. Some have nerve defects and others have middle ear trouble. All have certain conditions in which they do fairly well and others under which they fail sadly. Each has a different percentage of hearing left when first approached.

Once your sufferer has decided to try a hearing aid the trouble is just beginning. Noises which we commonly ignore, but which he hasn't heard for a long time, suddenly impinge on him and make him so nervous he can only stand the instrument for a short time each day at first. He has generally lost what is called a lot of his "sound vocabulary" so that many words with which he is familiar when written have lost their meaning to him when heard.

There is a lot of bother to adjusting and wearing the instrument, and quite an effort to be made focusing his attention on what he hears after so long a time of inattention. He has been so used to loneliness that suddenly getting back among friends in ordinary fashion makes him quite shy. He has been artfully trying to conceal his affliction for so long that suddenly advertising that he is attempting to alleviate it is unthinkable. Hence every contrivance for concealing the instrument is used--the amplifier under the shirt--the wire behind the neck and in the hair--the flesh-colored ear-piece--the batteries in the purse or hip pocket.

As you might guess, many are able to get back to a happy, useful and well-rounded life and, although never cured, the efforts of themselves and those other interested ones are richly rewarding. Unfortunately there is a tragic percentage for whom the effort is too great. Their instruments go into the ash-can and they retire to the silent half-life convinced that everybody is whispering.

Yes, they are a odd lot, but you have seen some others like them if you have been doing any Twelfth Step work lately and do *you* remember when? Keep your batteries charged, kids.

Reprinted w/permission AA Grapevine, Inc

Another for St Patrick's Day:

A GENT walked into a London pub and said, "I'll have an Irish cocktail."

"And what would that be?" asked the bartender.

"It's an ounce of Irish whiskey," said the customer, "with another ounce of the same added."

Reprinted w/permission of AA Grapevine, Inc., February 1980, Vol. 36, No. 9

Sponsorship Is a Two-way Street

I was exceptionally skeptical the first time I heard someone say, "Sponsorship helps the sponsor at least as much as it helps the newcomer." I thought that sounded too much like what my father would say when he was giving me a whipping: "This hurts me more than it hurts you." Sure, sure.

As far as I could tell, sponsorship was yet another form of authority. I liked it and hated it that way. I wanted a sponsor to give me all the "right" answers to my problems and the problems of the world, but I would buck against him whenever he gave me unsolicited or undesired advice.

That thinking pretty much determined the kind of sponsor I became during my second year. I was an authoritarian sponsor in spite of the fact that during my eighth or ninth month I met a guy whose words, actions, and manner consistently demonstrated a sponsorship style which transcended the authority/subservient presumption. That man is my sponsor today. But I learned how to be a sponsor like he is from my sponsees at least as much as I learned from him.

I worked with some newcomers during my second year. I tried to use fear, guilt, and a drill sergeant's voice to motivate them. I gave each one reading assignments from Conference-approved literature, writing assignments, and lots and lots of lectures. I would never share from my own experience, weakness, and despair because that might tarnish

my authority in their eyes.

But I did welcome one really struggling newcomer to my apartment for two days. He wanted to stay longer but I insisted that he find his own place; this turned out to be good for us both. I insisted that another call me each day from rehab. That kept the memory so green for me. Meanwhile, giving all those reading assignments kept me really busy. I had to reread all the literature I had assigned so that I could answer any sponsees' questions "perfectly" like a true authority. That's how being a sponsor began to help me.

Two of the guys fired me. Boy, what a blow to my ego. I hoped that they would find other sponsors but was secretly glad to be free of them. At least, that's what I said. One dropped me, I think, because I never opened up to him. He said I never admitted to him that I "made mistakes, too." The other told me that I was constantly criticizing him without complimenting his small steps in the right direction.

Boy, were they both right! But I didn't drink over being wrong and those two guys are still sober. So, by the grace of God, is the one who didn't fire me. It was a tough competition between God and me to see which of us was the true sponsor for these guys, but it was never close. The God of our understanding got each one of us through.

Sponsoring began to work for me

(“Sponsor” Continued on page 16)

CLUB INFORMATION

St. Patty's Dinner



Dinner and Dance \$12.00
Speakers Meeting Free

Saturday March 19th
Dinner @ 5:30pm
Speakers @ 7:00pm
AA — TBA
Al-Anon — TBA

Menu
Corn Beef
Cabbage
Northern Ireland Baked Chicken
Irish Potato's
Garlic Green Beans
Glazed Carrots
Dessert

Pass It On Club 6229 W. Forest Home Ave (414) 541-6923

About 2 Blocks Northeast of the corner of Howard & Forest Home Ave



Sponsored By:

Saturday Morning Early Bird Group

Purchase tickets at counter or from a board member



AA Grapevine, Inc. Vol 16, Issue 10, March 1960



"I wasn't being honest with myself. I found out I was staying sober for my boss—and the hell with him!"

NEW DAY CLUB

11936 N. Port Washington
Mequon, (262) 241-4673
<http://www.newdayclub.org>

A.A. MEETING SCHEDULE

Sun. 8:00 a.
11:00 a.
5:00 p. Young People
7:30 p. Sun. Night Topic

Mon. 12:30 p. Tenth Step Gp
5:30 p.
7:00 p.
8:15 p. Men's Gp

Tue. 10:00 a.
5:30 p. Topic Meeting
7:00 p. Beginners Gp
8:00 p. Big Book Gp

Wed. 10:00 a.
2:00 p. Promises Meeting
5:30 p. Step Meeting
7:30 p. Women's Gp

Thr. 10:00 a. Topic Meeting
1:00 p. Women's Gp
5:30 p. Topic Mtng.
8:00 p. Step Meeting

Fri. 10:00 a. Topic Meeting
5:30 p. Step/Tradition
8:00 p.

Sat. 10:00 a. Step Meeting
5:00 p. Steps/Principles
7:00 p. (Feelings)
10:00 p. Young People

8:00 p. Open Meeting (held on 3rd Saturday of month only)

AL-ANON MEETINGS

Monday 6:30 p. Al-Anon
Tuesday 1:00 p. Al-Anon/ACOA
Thursday 7:00 p. Al-Anon
Contact club for info on other fellowships.

PASS IT ON CLUB

6229 W. Forest Home Ave Milw, WI
(414) 541-6923 passitonclub.com

A.A. MEETING SCHEDULE

Sun. 8:00 a. Sun. Wake Up
9:30 a. Reliance Open Disc.
11:00 a. Today choice
3:00 p. Gratitude Plus
7:00 p. Big Book Readers
7:30 a. Jump Start
10:30 a. First Step
4:00 p. Happy Hour Step

Mon. 7:00 p. Mon. Freedom
7:00 p. Open IntroductoryAA
Tue. 7:30 a. Comin' Back Gp
10:30 a. Keep It Simple
4:00 p. Drop the Rock
6:00 p. Women's Step
7:30 p. Three Legacies
7:30 p. Double Trouble DD/O

Wed. 7:30 a. Big Book Study
10:30 a. Pass It On
4:00 p. Happy Hr Promises
7:00 p. We, Us & Ours

Thr. 7:30 a. Welcome Back Gp
10:30 a. Made Decision
5:15 p. As Bill Sees It
7:00 p. Gateway Topic Gp
7:30 a. Honesty Gp

Fri. 10:30 a. Came To Believe
6:00 p. Women's Fri. Kickoff
6:30 p. Thoughts 4 Today
8:00 p. Spanish Speaking
8:00 p. Group # 1

Sat. 8:30 a. Early Bird
10:30 a. Happy Joyous Free
3:00 p. Twelve Promises
8:00 p. Back to Basics

12x12

AL-ANON MEETINGS

Sun. 11:00 a. Thr. 7:00 p.
Tue. open (Alateen)
Wed. 7:00 p. Fri. 7:30 p.
Sat. 10:30 a.

LAKE AREA CLUB

N60 W 35878 Lake Dr
Oconomowoc, WI
(262) 567-9912

Visit our website at:
www.lakeareaclub.com

A.A. MEETING SCHEDULE

Sun. 8:00 a.
11:00 a.
6:00 p. Big Book
8:00 p.

Mon. 9:00 a. Positive Attitude
6:30 p.
8:00 p. Step/Tradition Stdy

Tue. 1:00 p.
8:00 p. Back To Basics

Wed. 8:00 a.
10:00 a.
6:00 p.
8:00 p.

Thr. 10:00 a.
6:00 p. Women's Group
8:00 p.

Fri. 12:30 p.
6:00 p. Non-smoking
8:00 p.

Sat. 8:30 a.
10:00 a. Big Book
8:00 p.

AL-ANON MEETINGS

Mon. 8:00 p. Al-Anon
Tue. 9:00 a. Al-Anon
Wed. 7:00 p. Al-Anon

OPEN SPEAKER MEETING

Sat. 7:00 p. 2nd & 4th Saturdays
(AA and/or Al-Anon Speakers)

WAUKESHA ALANO CLUB

318 W. Broadway
Waukesha, WI
(262) 549-6541

A.A. MEETING SCHEDULE

Sun. 11:00 a. Sun Go-To-Mtng
(Open speaker 2nd Sunday & Breakfast)
7:00 p. (Open Step Gp)

Mon. 12:00 Noon
6:00 p. Beginners AA
7:00 p. (12 & 12)

Tue. 12:00 Noon

Wed. 12:00 Noon
5:30 p. Topic Gp
8:00 p.

Thr. 12:00 Noon
8:00 p.

Fri. 12:00 Noon T.G.I.F. Gp

Sat. 10:00 a. Gp 124
7:00 p. Closed Meeting

**OPEN MEETINGS,
DANCES & EVENTS**
Call for information.

UNITY CLUB

1715 Creek Drive
West Bend, (262) 338-3500
<http://www.unityofwb.com>

AA MEETING SCHEDULE

Sun. 10:30 a.** Gratitude Gp.
8:00 p.* Candlelight Gp.

Mon. 10:00 a. Monday A.M.
7:00 p. Men's

Tue. 10:00 a. Tuesday A.M.
7:30 p. Beginner's
8:00 p. Step Gp

Wed. 10:00 a. Promises
8:15 p. Step Gp

Thr. 10:00 a. Big Book
8:00 p. Young People

Fri. 10:00 a. Step/Topic Gp
8:00 p.*** Step Gp.

Sat. 10:00 a. Here & Now

AL-ANON & ALATEEN MTNGS

Monday 6:30 p. Alateen
Wednesday 8:15 p. Al-Anon

* Open Mtng. 1st Sunday Quarterly
** Open Mtng. 3rd Sunday of month (a.m.)

*** Open Mtng. last Friday of month

SERENITY CLUB

3677 E. Pulaski Ave,
Cudahy, WI 53110,
(414)483-8308
serenityclub.info

AA Meetings

Sun. 10:00 a. Welcome Gp.
7:00 p. Gp. 83

Mon. 10:00 a. Honesty Gp.
6:30 p. Ladies Big Book
8:00 p. Sharing Strength

Tue. 10:00 a. Gp. 118
8:00 p. Gratitude Gp.

Wed. 10:00 a. Rap Discussion
5:30 P. Courage/Change
8:00 p. 1 Day At A Time

Thr. 10:00 a. Gp. 89
8:00 p. Gp. 88

Fri. 10:00 a. Gp. 41
6:30 p. Broken Arrow
8:00 p. Gp. 449

Sat. 10:00 a. Reliance Gp.
7:00 p. Big Book Gp.

AL-ANON MTNG: Sunday 5:30 p.
AL-ANON MTNG: Tuesday 6:30 p.
ALATEEN MTNG: Tuesday 6:30 p.
AL-ANON MTNG: Friday 7:30 p.

Call Club for Open Meeting
& Dance Information

CLUB INFORMATION

WALWORTH COUNTY ALANO CLUB

611 Walworth St.
(Hwy. 50 & 11)
Delavan, WI 53115,
(262) 740-1888

Sunday AA

10:00 a. Primitive Group
12:00 Noon Open Speakers
6:30 p. Delavan Discussion

Monday AA

7:30 a. Delavan Sunny Side Up
12:00 Noon Delavan Step Meeting
6:30 p. Former Miss Americas
(Women's Step Group)
6:30 p. Delavan Men's Meeting

Tuesday AA

7:30 a. Delavan Sunrise Tue
12:00 Noon Delavan Noon Gp.
6:30 p. Delavan 12 Step Topic

Wednesday AA

7:30 a. Delavan Sunrise Wed.
12:00 Noon As Bill Sees It Gp.
6:30 p. Delavan IT Meeting

Thursday AA

7:30 a. Delavan Sunrise Thr.
12:00 Noon Delavan Noon Gp.
5:30 p. Step Sisters Women
6:30 p. Delavan Big Book Gp.

Friday AA

7:30 a. Delavan Sunrise Fri.
12:00 Noon Big Book Study
6:30 p. Delavan Discussion
8:00 p. Delavan Candle-less Gp.

Saturday AA

12:00 Noon Delavan Noon Gp.
6:30 p. Delavan Beginners Gp.

ALANO CLUB 1521 N. Prospect Ave.
Milwaukee, WI (414) 278-9102
<http://www.alanofoundation.com>

A.A. MEETING SCHEDULE

Sun. 10:00 a. Gp 17 Step
4:30 p. Step Gp.
7:30 p. Gp 19 Step
10:00 p. Topic Gp.
Mon. 7:00 a. Early Morning
10:30 a. Gp 72 Topic
12:15 p. Big Book Meeting
5:30 p. Gp 12 Monday Blues
6:30 p. Gp 40 Big Book
8:00 p. Gp 20 Topic
10:30 p. Living Sober Step/Topic
Tue. 7:00 a. As Bill Sees It.
10:30 a. Gp 70 Step
12:15 p. Gp 76
5:30 p. Men's AA & Al-Anon
8:00 p. Beginners - 1st Step (3rd fl)
8:00 p. Gp 57 Topic
10:30 p. 4th Dimension Step/Topic
Wed. 7:00 a. Men's Step
10:30 a. Gp 9 Step
12:10 p. Oasis Topic Gp
6:00 p. Gp 91 Women's
8:00 p. Gp 3 Step/Topic
10:30 p. Step/Topic Gp
Thr. 7:00 a. Big Book Meeting
10:30 a. Gp 97 Step
12:15 p. Here & Now Gp
5:30 p. Acceptance Topic
7:00 p. LGBT Big Book
7:30 p. Gp 26 12x12
10:30 p. As Bill Sees It
Fri. 7:00 a. Daily Reflections
10:30 a. Gp 21 Step
12:15 p. Gp 65
6:30 p. Here & Now
8:30 p. Gp30 Tub Topic
11:30 p. Step/Topic
12:15 a. Second Shifters
Sat. 11:00 a. Gp 87 Step
3:00 p. Spiritual Growth
7:30 p. Open Speaker
9:00 p. Here and Now
11:30 p. Tub-Topic

AL-ANON MEETING Sunday 10:00 a.
Club is smoke free. Many meetings break
outdoors for smoking.

H.O.W. TO CLUB

8930 W. National Ave,
West Allis, (414) 543-2448

<http://howtoclub.info/>

Sun. 8 a.-11 p.
Mon - Thr. 9 a. - 11 p
Fri - Sat. 9 a. - 1 a.

AA MEETING SCHEDULE

Sun. 8:00 a. Eye Opener AA Gp.
10:00 a. Grass Roots (Steps)
4:30 p. Drop the Rock 6/7 Step
6:00 p. AA Topic Group
8:00 p. Sun. Sober & Serene
Mon. 11:00 a. Winner's Circle
5:45 p. Gp 132, Women's Gp
7:00 p. Big Book Gp.
8:00 p. New Hope Gp.
11:15 p. Nighthawk Gp.
Tue. 11:00 a. Willingness Group
6:00 p. Tuesday Non-Smok
8:00 p. 12 & 12 AA Meeting
Wed. 10:00 a. Foundations Meeting
6:00 p. AA Beginners Gp.
7:00 p. Women's Freedom
8:00 p. Promises Group
11:15 p. After Hours Gp.
Thr. 10:00 a. But For Grace Of God
6:00 p. 6 PM Here and Now
8:00 p. How To Get It Going
Fri. 11:00 a. Priority Group
6:00 p. Big Book Group
8:00 p. R.U.S. For Us
11:15 p. Candlelight Promises
Sat. 9:15 a. Men's Topic
11:00 a. Pioneers Group
6:00 p. 1st & 12 Topic
8:00 p. HOW To Saturday*)
*(Open meeting on 3rd Saturday)
10:30 p. Candlelight Gratitude

CLUB INFORMATION

FRIENDSHIP CLUB

2245 W. Fond du Lac
Ave. Milwaukee, WI
414. 931.7033

AA MEETING SCHEDULE

Sunday:
10:00 a. Friendship Gp
11:00 a. Third Sunday
Open Meeting

Monday:
10:30 a. Step Gp

Saturday:
10:00 a. Gp 112

**Call for information on
other types of
meetings.**

12 STEP CLUB

4102 W Townsend St.
Milwaukee, WI 53216
(414) 871-0610

A.A. MEETING SCHEDULE

Sun. 10:00 a. Gp. 24 Upstairs
Mon. 11:00 a. Gp. 92
Tuesday **No AA Meeting**
Wed. 11:00 a. Gp. 27
Thursday 07:00 p. Here & Now
Fri. 11:00 a. Gp. 61 (12x12)
6:00 p. Women's Gp.
Sat. 10:00 a. Beginners Gp.
7:00 p. Gp 6

**CALL THE CLUB FOR
INFORMATION ON OPEN
A.A. MEETINGS,
MEETINGS FOR OTHER FEL-
LOWSHIPS and
SPECIAL EVENTS.**

1907 CLUB

2908 N 21st St.
Sheboygan, WI 53083
(920) 457-9633

AA MEETING SCHEDULE

Sun: 7:00 p. As Bill Sees It
Mon: 6:30 p. Old Timers
7:30 p. Women's
8:00 p. Beginners
Tue: 6:00 p. Big Book
Wed: 9:30 a.
8:00 p. WITTSS
Thr: 6:00 p. Topic Meeting
7:00 p. Closed Speaker
Fri: 8:00 p. Good Fight Gp
Sat: 9:30 a. Non-Smoking
6:30 p. Grapevine
MtnG
**Open Meeting 1st & 3rd
Saturday of month at 8:00 p.**

Al-Anon Meetings

Monday: 7:00 p. Al-Anon
Wednesday: 9:30 a. Al-Anon
Saturday: 9:30 a. Ala-teen
9:30 a. Ala-Tot
9:30 a. Al-Anon

24 HOUR CLUB

153 Green Bay Rd.
Thiensville, WI
(262) 242-9999

A.A. MEETING SCHEDULE

Sun. 8:00 a. Topic
10:00 a. Step/Topic
5:00 p. Step
Mon. 6:30 a. Topic
10:00 a. Topic
12:00 p. Women's
8:00 p. Men's
Tue. 6:30 a. Topic
10:00 a. Step/Topic
5:30 p. Big Book
Wed. 6:30 a. Topic
10:00 a. Big Book
5:15 p. Women's
Thr. 6:30 a. Topic
10:00 a. Topic
5:30 p. Step/Topic/Trad
Fri. 6:30 a. Topic
10:00 a. Step/12 & 12
5:30 p. Principles
8:00 p. Step
Sat. 8:30 a. Living Sober
10:00 a. Big Book

**8:00 p. Open Speaker Mtng.
(1st Saturday Only)**

GALANO CLUB

- LGBT Recovery -

315 W. Court St. Suite 201
Milwaukee, WI 53212-3825
(414) 276-6936

<http://www.galanoclub.org/>

mail@galanoclub.org

MEETING SCHEDULE

Sun. 10:30 a. Step Topic
Mon. 7:30 p. Came To Believe
Tue. 5:30 p. 40+ Topic
Wed. 7:00 p. 12 x 12
Fri. 7:00 p. Step/Topic
Sat. 7:30 p. Topic

AL-ANON MEETINGS

Sun. 10:30 a.m. (Co-ed.)

**CALL THE CLUB FOR INFO ON
SPECIAL EVENTS AND OPEN
MEETINGS!**

NORTHWEST ALANO CLUB*

N88 W17658 Christman Rd
Menomonee Falls WI
53051 (No Phone)

A.A. MEETING SCHEDULE

Sun. 7:30 p.
Mon. 7:00 p.
8:00 p. Action Gp
Tue. 10:00 a. Step
8:00 p.
Wed. 8:00 p. Step/Topic
Thr. 10:00 a. Step
6:00 p. Women's
Fri. 8:00 p. Step/Topic
Sat. 10:00 a. Step

AL-ANON MEETINGS

Wed. 8:00 p. Al-Anon
Fri. 8:00 p. Al-Anon

*This Club is a Smoke-Free
environment. We have ample
meeting space available for 12 Step
groups. Contact the Northwest Alano
Club by mail.

The "Clubs" listed here are not A.A. Clubs. **A.A. DOES NOT HAVE CLUBS!**
A.A. neither endorses nor opposes such clubs. These are social clubs established by groups or individuals who are themselves recovering alcoholics. The A.A. group meeting at the club is available to any alcoholic - club member or not. The group is separate from the club and pays a fair rent for the use of the club facilities. Even though the group meets in a club that may be composed exclusively of A.A. members, and many members of the group may be club members, too, the relationship of the A.A. group itself to the club should be the same as it would be to a church, hospital, school, etc., in which it might rent space for its meetings.

When and Where

NEW MEETINGS

Women's Big Book, Christ Church
13460 N Port Washington Rd, Me-
quon 53092, meets on Mondays at
6:00 p.

**Polish Sober Eagles (Polish
Speaking)** Prince of Peace, 4419 S
Howell Ave Milwaukee 53207 (rear
parking, rear entrance) Meets on
Tuesday and Friday at 6:00 p.
(Russian Interpreter available)

**Bright Spot of Our Lives Young
People**, St James Congregation
W222 N6570 Town Line Rd, Meno-
monee Falls Wednesdays at 7:00 p.
UW-Whitewater, Ambrose Health

Center, 800 W Main St, Whitewater,
Wednesdays at 4:00 p.

By The Book, Tippecanoe Presby-
terian, 125 W Saveland Ave Mil-
waukee 53207 Wednesday, 7:00 p.

LGBT Friendly, Milwaukee Metro-
politan Community Church, 1239 W
Mineral St. Milwaukee 53204.
Thursdays at 6:30 p.

DISBANDED GROUPS

**Fight the Good Fight Open, Ace
Boxing Club**, 2160 S 10th, Milw.
met on Mondays at 7:00 p.

Muskego Wednesday Night, met
at Heritage Presbyterian, 13761
College Ave, Muskego, at 7:30 p.

Brown Deer Friday, Abiding Savior, 5214 W Luebbe Ln, met on Fridays at 8:00 p.

Cudahy Into Action, Cudahy United Methodist, 5865 S Lake Dr. Cudahy, met Saturdays at 7:00 p.

OTHER CHANGES

Time To Start Living, Brookfield Presbyterian, 1485 Brookfield Rd, Noon on Mondays, now has an **open meeting on the last Monday** of the month.

Cedarburg Tue Gp, Advent Lutheran W63 N642 Washington Ave, Cedarburg, formerly met at 8:00 p. on Tuesday, now meets at 7:00 p.

Hartford Wednesday Night, time change, old time 8:00 p. **NEW time is 7:00 p.**

Friday Night Second Shifter's formerly met at Serenity Club, now meets at the Alano Club, 1521 N Prospect Ave Friday night/Saturday morning at 12:15am

Fri North Shore, Bay Shore Lutheran, 1200 E Hampton, formerly at 8 p. now meets at 7:30 p.

Holy Hill Friday, is now **Hartford on the Hill** and meets at Hartford Savings Bank, 1400 Schauer Dr in Hartford 53027 at 7:00 p. Friday.

OPEN MEETINGS

Weekly & monthly open meetings listed in December 2010, When & Where

aamilwaukee.com/directory.html

Grapevine Open Meeting, Pass It On Club, 6229 W. Forest Home Ave. meets on **Sundays at 5:00 p.**

AA OPEN MEETING at the VA, 5000 W National Ave, Milwaukee, Dom 43 Cafeteria, **Monday November 8, 7pm**

West Allis Memorial Hospital, (Conf. Rm. B), 8901 W. Lincoln Ave., **Sundays at 4:30 p.** Ace Boxing 1st Monday Open Meeting, 2160 S. 10 St., Milw.,

meets **1st Monday at 7:00 p.**

Bethesda Seniors Community Center Open Meeting, 2845 W Fond du Lac Ave **1st Monday at 1:30 p.**

Salem United Methodist Church, 541 Hwy. 59, Waukesha, ea. **Wed. 7:00 p.**

St. Lukes Church, 300 Carroll St., Waukesha **1st Friday only 8:00 p.**

24 Hour Club Open Meeting, 153 Green Bay Rd, Thiensville, **First Saturday of month at 8:00 p.**

New Hope United Church, 4360 N. Jackson Dr., Jackson WI, meets on **Second Saturday only at 7:00 p.m.**

Dist 34, St. Francis Episcopal Church, N84 W16525 Menomonee Ave., **Second Saturday at 7:00p.**

Waukesha Alano Open Mtng. 318 W. Broadway, Waukesha, **2nd Sunday, at 11:00 a.**

Open Meeting 2245 W. Fond du Lac Ave. Milwaukee, WI. Meets on **3rd Sunday at 11:00 a.**

HOW To Club Open Meeting, 8930 W. National Ave., **3rd Saturday 8:00 p.**

New Day Club Open Meeting, 11936 N. Port Washington Rd, Mequon, **Third Saturday at 8:00 pm**

Trinity United Church of Christ, 4435 N. Calhoun Rd. **Last Wed. 8:00 p.**

Holy Assumption School, 72nd & Orchard, **Last Wednesday 8:00 p.**

Hartford on the Hill Open Meeting, Hartford Savings, 1400 Schauer Dr Hartford WI, **3rd Friday of May and September at 7:00 p.**

New Day Club Open Meeting, 11936 N. Port Washington Rd., Mequon, **Third Saturday at 8:00 p.**

Alano Club Open Meeting, 1521 N. Prospect Ave **Every Saturday 7:30 p.**

Contact the Central Office, E-mail: gmco@aamilwaukee.com, before the 12th of the month prior to your Open Meeting so that it can be listed here under the special/ anniversary Open Meetings section.

5/5

"Faithful Fivers"

Greater Milwaukee Central Office
7429 W. Greenfield Ave. West Allis WI 53214

Faithful Fivers "When we meet and defeat the temptation to take large gifts, we are only being prudent. But when we are generous with the hat, we give a token that we are grateful for our blessings and evidence that we are eager to share what we have found with those who still suffer." - *Bill W.*

Every single AA service is designed to make 12th Step work possible. As a **Faithful Fiver** your personal contributions can and will make our vital services possible. You can start with a minimum monthly contribution of \$5.00 or more. This can be paid by check or billed to your credit card.

Yes! I want to participate in the Faithful Fivers Club.

Contribution Information: Date: _____
Amount \$: _____ **Monthly** _____ **Quarterly** _____ **Annually** _____

(Note no AA member can contribute more than \$3000 per year)

I am a new member _____ a current member _____ a returning member _____.

Payment Plan:

Check enclosed: _____ or Bill my credit card: Visa _____ M/C _____ Discover _____

Card #: _____ - _____ - _____ - _____

Expiration Date: ____/____/____

Name _____

Address _____

City _____ **State** _____ **Zip** _____

Phone Number (____) _____ - _____

2011 Weekend Retreats Jesuit Retreat House, Oshkosh, WI jesuitretreathouse.org

Men and Women members of AA, Al-Anon
Total cost: 4 days \$290.00. Send a \$40.00 deposit with requests for specific dates to: Jesuit Retreat House, 4800 Fahrwald Road, Oshkosh, WI 54901 or call for information, 1(800) 962-7330
May 5-8 Men, Fr Peter O'Brien, S.J.
May 12-15 Women, Fr: Tom Weston, S.J.
May 19-22 Men, Fr Tom Weston, S.J.
Aug 18-21 Women, Mildred Frank
Nov 10-13 Women, Sr Kerry Larkin OSM
Nov 17-20 Women, Sr Elise Cholewinski OSF
Dec 01-04 Men, Fr Kevin Ballard, S.J.

Spanish Speaking Meetings: Meeting at English Speaking Clubs

- GRUPO 5 CONCEPTOS, Pass It On Club, 6229 W. Forest Home Av, Milw, on Friday at 8:00 p.
- GRUPO NUEVO AMANECER, Tri-County Unity Club, 104 N. First St, Watertown, on Tuesdays and Fridays at 7:00 PM and on Sunday at 11:00 AM
- GRUPO FE Y ESPRONZA, Gratitude Club, 295 Ruggles St. Fond du Lac WI on Wednesday at 7:00 PM and Sundays at 4:00 PM

MILWAUKEE CENTRAL OFFICE

- **E-mail the Board President at:** board@aamilwaukee.com
- **E-mail Director Jim B. at:** jim@aamilwaukee.com
- **Hours:** 9 a.m. to 6 p.m. Mon.-Fri.; 9 a.m. to 5 p.m. on Saturday
- **G.S.R. Orientation, 2nd** Tuesday 6:30 p.
- **Secretary Meeting, 2nd** Tuesday 7:00 p.
- **Board of Directors Meeting,** Wednesday following Secretaries Meeting, (odd numbered months) 7:00 p.
- **A. A. Meetings,** Mon - Fri at 12:15 p. and 4:00 p.
- **A. A. Meeting Saturday** 10:30 a. and 3:00 p.
- www.aamilwaukee.com

JAMBOREE 2011



Milwaukee County Zoo, Peck Welcome Center
10001 W. BLUEMOUND RD.

SATURDAY SEPTEMBER 17, 2011
HOSPITALITY: 5:00 P.M., DINNER: 6:00 P.M.
SPEAKER: Mildred F. / Toronto, 7:00 P.M.
Dance to follow

\$25.00 Soda and Water Only \$1.50 **\$25.00**

Tickets by mail, \$25.00 each. Include a self addressed stamped envelope:
 Greater Milwaukee Central Office 41st Annual City Wide Jamboree
 7429 W. Greenfield Ave., West Allis, WI 53214, 414-771-9119

Pay by check or credit card, Visa/MasterCard/Discover, include all necessary information.
 Card Number _____ Expiration Date ____ / ____
 Name _____ Phone _____ CID# _____
 Address _____ Zip Code _____
 Number of tickets _____ X \$25.00 = Total \$ _____ E-mail Address Please: _____

Zoo Admission and Parking are included with Jamboree ticket purchase.

(“Sponsor” Continued from page 8)

later. I prayed to God to let me give more service during my third year. I knew I needed that in order to maintain my sobriety. At that time, I no longer had any sponsees. Within hours of praying for a chance to serve, God presented me with an interim sponsee. We hit it off immediately. Listening had become a lot easier for me. I tried new ways of making firm suggestions. After all, this would be a learning experience for me, too. More frequently than not, I considered the fragile feelings of my sponsee before biting off his head. I tried to toss out possibilities and suggestions without the tone of

someone laying down the law. But when I knew in my gut that he needed to hear a blunt message, I gave it to him straight. Finally, and most importantly, I think, I began to share with him what I had previously only shared with my sponsor: what was going on with me. I became vulnerable. And I didn't pick up a drink, a day at a time.

I have learned many lessons from my current sponsee and from the former ones who are still in touch with me from time to time. Try sponsorship. It works.

Robert P.
New York, New York

Reprinted w/permission AA Grapevine, Inc

DISTRICT 16 PRESENTS
Our 2nd Annual
OUR MARCH INTO SOBERITY
AN CEEN SPEAKER MEETING



Where: Milwaukee Central Office
7429 West Greenfield Avenue West Allis, WI 53214

When: March 6th 2011

Hospitality starts at Noon

AA Speakers start at 1:00 pm

First Speaker: Paul E. (Milwaukee)

Second Speaker: Mike C. (Manitowoc)

Please come join us, there will be District 16 Chair people to answer questions and share information about how we can carry the message to all in our district and beyond



Coffee and snacks will be available

Please feel free to bring your favorite snack to share

Volunteers Needed To Staff the Archives Room

GOAL

Keep the Archives Room Open
From Noon until 4:00 Sunday's
throughout the year of 2011

Volunteers can sign up for one day
or as many days that
they are able to commit to.

Please contact Nancy Seelen
Area 75 Archivist
414 339-3934
aanancy@att.net

RESERVE THE DATE FOR A GREAT WORKSHOP



March 19th & 20th, 2011

Over two days, we cover the 12 steps of
AA as discussed in the first 164 pages of
the Big Book, Alcoholics Anonymous.

Mike & Ray, from St. Pete, FL, discuss
the History of AA and walk us through
the 12 Steps as was done back in the 40s
by early groups of AA.

COME JOIN DISTRICT 29 BI-MONTHLY OPEN MEETING ROUND ROBIN

Where : Emmanuel United Church of Christ
19527 West Forest Home Ave - Hales Corners, WI

Time: 7:00 pm A.A. and Alanon Speakers Carry Their Message

Dates: The second Sunday of the following months
Mark your calenders for these dates

February 13	A Vision For You
April 10	Group 69
June 12	TBA
August 14	TBA
October 9	Saturday Morning Early Birds
Decembre 11	TBA

COME JOIN US FOR
FELLOWSHIP, UNITY, AND RECOVERY



I am responsible. When anyone, anywhere, reaches out for help,
I want the hand of AA always to be there.
And for that: I am responsible

Written for Us Newcomer's Meeting *An Insight to 'How it Works'* A meeting for newcomers and/or old-timers

when:
Saturday's from 9:15 to 10:15am

where:
Greater Milwaukee Central Office
7429 West Greenfield Avenue
West Allis, WI 53214
414.771.9119

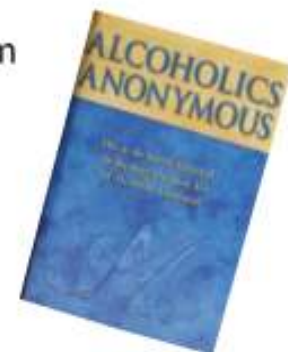

Come JOIN US & learn more about Alcoholics Anonymous

SATURDAY BREAKFAST BUFFET

Served from 8am to 10am.

PASS IT ON CLUB
6229 W.
Forest Home Ave
Milwaukee, WI 53220
414-541-6923

BREAKFAST DATES

January 8, 2011
February 12, 2011
March 12, 2011
April 9, 2011

Menu

- Scrambled Eggs
- Sausage
- Pancakes
- Fruit Cup
- Juice
- Milk

Tickets sold at door
\$5.00



35th Annual

BADGER

Architect in Diversity

INTERGROUP!

SATURDAY

March 26, 2011

Waukesha Expo Center
(non-smoking facility)

Speaker: Clancy I.
from Los Angeles, CA

Social Hour – 5:30 pm
Dinner – 6:30 pm
Speaker – 8:00 pm

Dance to follow

Coffee & Soda Available

Tickets: \$24.00 each

(PROCEEDS WILL BE SPLIT)

All Sales are Final – No Refunds

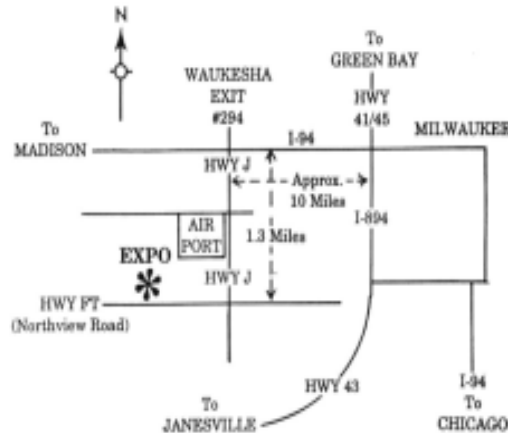

TICKETS BY MAIL-IN ONLY.

Payment must be received by **February 26, 2011.**

Tickets will **NOT** be sold *at the door.*
THIS FLYER MAY BE REPRODUCED

"We absolutely insist on enjoying life."

MAIL TEAR-OFF SECTION TO: Christine Hutchinson 3929 S Troy Ave, St. Francis, WI 53235,
262-227-4836

NAME: _____ PHONE: _____

ADDRESS: _____

NUMBER of TICKETS: _____ x \$24.00 each = AMOUNT ENCLOSED: \$ _____

Check Payable to: Badger Intergroup

____ A.D.A. Accessible Seats Needed

All Sales are Final!

THANK YOU!



AA: Women to Women

This is a closed AA meeting

A day of sharing:

To foster the sharing of ideas, feelings & issues

To create a safe atmosphere that nurtures honesty & becoming

To explore the positive energy among AA women

9:00 - 9:30 Registration/ Coffee

9:30 - 9:45 Opening/Announcements

9:45 - 10:30 Why Do We Feel So Alone

10:30 - 10:45 Break

10:45 - 11:30 It Doesn't Happen Overnight

11:30 - 11:45 Break

11:45 - 12:30 Secrets Women Don't Share

12:30 - 1:30 Lunch

1:30 - 2:15 How Do I Nurture Myself

2:15 - 2:30 Closing/Countdown

Saturday April 30, 2011
9:00am - 2:30pm

The Pass It On Club
6229 W. Forest Home Ave.
Milwaukee, WI 53220
414-541-6923

For more information contact:

Joy S. 262-215-7513

Cyann R. 414-614-3028

Registration Form

Deadline: April 23, 2011
Registration fee: \$10.00

Please use a separate form for each person
Includes: Lunch Buffet, Coffee, Doughnuts

Please print:

Name: _____

Address: _____

City, State, Zip: _____

E-mail: _____

Make checks payable to: Women to Women
Mail to: Women to Women c/o Joy Steinbicer
3251 S. 54th St Milwaukee, WI 53219